



Address 125

Press information

October 2022



Contents

1. Introduction	P3
2. Product concept	P4
3. Styling design	P7
4. Engine	P8
5. Chassis	P18
6. Electric equipment	P26
7. Genuine accessories	P29
8. Colour lineup	P30
9. Specification	P31



1. Introduction

The new Address 125 encapsulates classic urban style in a package wrapped around a Euro 5 engine that is all about optimising fuel economy and low CO₂ emissions, while delivering a punchy riding experience with proven reliability. Add in a suite of practical touches and the Address 125 combines convenience and city riding pleasure.



2. Product concept

The Classic Commuter

The concept reflects the fact that the Address 125 excels as a stylish urban scooter, whether it's used as a daily commuter or as a practical ride for tackling everyday tasks.

Its performance attributes and proven reliability come from the Suzuki Eco Performance (SEP) engine, a compilation of cutting-edge Suzuki technologies. An advanced air-cooled engine design is coupled with a fuel injection system to achieve the best of both worlds: maximum power output with satisfying acceleration and optimum fuel economy combined with environmental performance that complies with Euro 5 emissions standards.

A combined brake system provides more balanced braking, and the use of bright, compact, and durable LEDs for the headlight and position lights provide greater visibility.

Features that contribute to rider comfort, convenience, and satisfaction include the classic design of a new, large analog speedometer that combines with a digital display to provide all the information the rider needs. The long, well-padded seat delivers a comfortable ride for both rider and pillion, and the long, wide floorboard provides plenty of room for the rider to adjust their feet and maintain a comfortable position.

Utility comes via generous storage space under the seat, convenient dual utility hooks, an easy-to-access front pocket, a standard-equipment USB outlet for charging smartphones, the Suzuki Easy Start System, and a tail-mounted petrol cap that facilitates easy refuelling.



2. Product concept

Key product features

Styling design:

- Classic design with timeless urban styling
- Combines the classic design of an analogue speedometer with digital information displays to provide all the information the rider needs in real time
- LED headlight and position lights are bright, compact, and efficient
- Integrated rear combination light accents the attractive appearance of the tail section
- Emblems with metallic finish lend a premium touch

Engine features:

- Advanced Suzuki Eco Performance (SEP) engine technology
- Simple, reliable, air-cooled SOHC engine design with a proven track record
 - *Over five million SEP engines in use worldwide*
- Combines prompt acceleration with low fuel consumption
- Excellent low and mid-range torque contributes to quick acceleration
- Compact and lightweight package contributes to fuel efficiency and better handling
- Optimisations throughout the engine deliver excellent combustion efficiency
- Low-friction engine design reduces friction loss for greater reliability and power efficiency
- Euro 5 compliant for environmentally responsible performance
- Excellent durability, long service life, low running cost, and easy to maintain



2. Product concept

Chassis features:

- Lightweight, rigid frame minimises weight and contributes to better handling
- Suspension delivers solid road-holding performance and a comfortable ride
- Dunlop D307 N tyres deliver excellent running performance and a smooth ride
- Cast aluminium wheels are light in weight and heavy in style
- Suzuki's Combined Brake System supports well-balanced braking by distributing braking force to both the front and rear wheels when the left brake lever is operated
- Short wheelbase and light, slim design contribute to easier, more agile handling
- Five litre fuel tank helps extend riding range
- Long, well-padded seat provides rider and passenger plenty of room and comfort
- Spacious floorboard helps maintain a comfortable riding position
- Large grab bar is easily accessible for a passenger, providing reassurance and comfort
- Rubber-covered pillion footpegs offer a pillion a more comfortable ride
- Locking tail-mounted fuel cap makes for easy refuelling

Practical features:

- One-push Suzuki Easy Start System makes for easy engine starting
- 21.8 litres of underseat storage
- Front inner pocket provides convenience and easy access
- USB outlet makes it easy to recharge a smartphone on the go
- Dual utility hooks are handy for carrying shopping bags and other items
- Theft deterrent key system with seat opener function adds convenience and security
- Standard equipment centre and side stands offer greater parking flexibility



3. Styling design

The Address 125 design concept was: Timeless and sophisticated.

Every aspect of the design aims to reflect the classic scooter styling, from its curvaceous form punctuated by attractive body lines and chrome-plated accents and emblems, to the large analogue speedometer complemented by a digital display. More than just a practical, fuel-efficient scooter that is ideal for everyday use, the Address 125 is designed to appeal to people who want to experience the timeless joy and exhilaration of two-wheeled urban freedom.



Distinctive emblems with bright metallic finish

Both the raised lettering of the emblems on the side panels and the Suzuki logo front and centre feature an attractive metallic finish with a premium feel.



4. Engine

Introduction

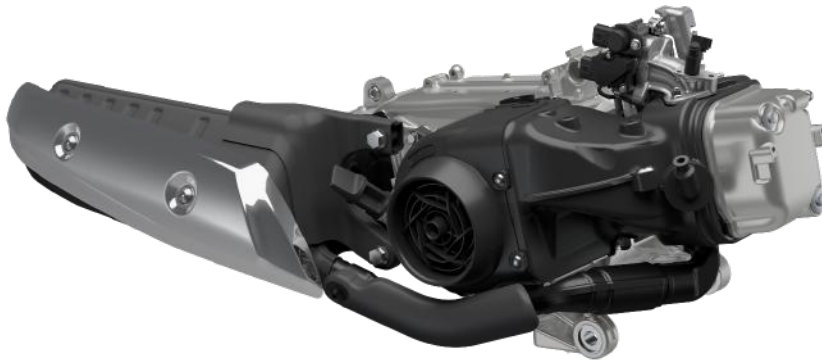

The Address 125 excels as an environmentally responsible scooter. Developed to comply with the stringent Euro 5 emissions standards, the Address 125 achieves outstanding fuel efficiency of 148.67mpg and CO₂ emissions of a mere 44g/km in WMTC mode testing.

The engine's single-cylinder, air-cooled design makes it a reliable powerplant that is easy to maintain and economical to run. Moreover, it is compact and lightweight, a feature that also contributes to agile handling.

Though being introduced into the UK for the first time, the engine can boast a proven track record of performance and reliability, already powering well over five million Suzuki scooters in Asian and Latin American markets.

Suzuki Eco Performance (SEP) is the forward-looking engine development concept behind the creation of the powerplant for the new Address 125. The resulting engine features an outstanding level of environmentally responsible performance, both in terms of low fuel consumption and low emissions, while also achieving the seemingly contradictory feature of dynamic performance, with powerful acceleration delivering immediate response when pulling away from a standing start with peak horsepower of 8.7PS and maximum torque of 10Nm delivered at low rpm.

4. Engine

Displacement	124cc
Engine type	Four-stroke, single-cylinder, air-cooled, SOHC
Bore x Stroke	52.5mm x 57.4mm
Maximum power	8.7PS (6.4 kW) / 6,750 rpm
Maximum torque	10Nm / 5,500 rpm
Fuel consumption (WMTC)*	148.67mpg
CO₂ emissions (WMTC)*	44 g/km
Emissions level	Euro 5

Engine Power and Torque

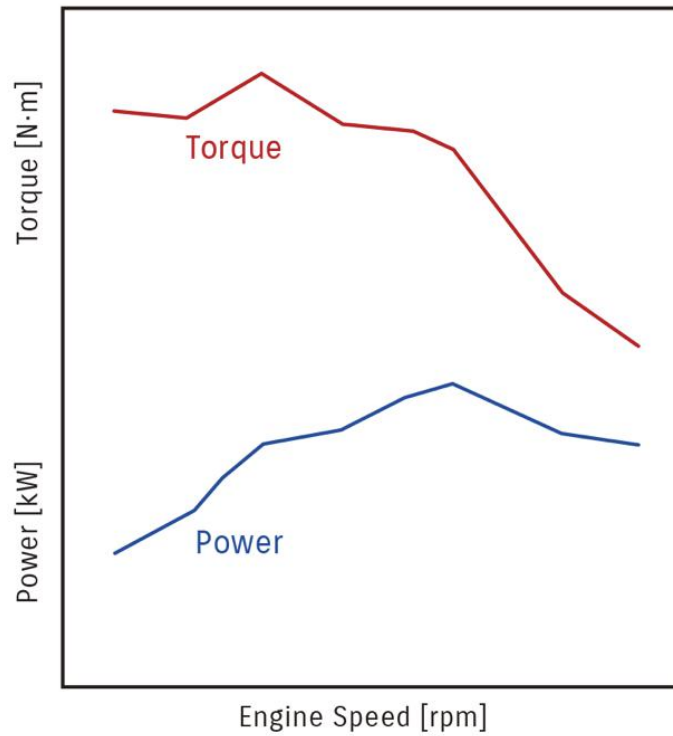

4. Engine Acceleration test comparison

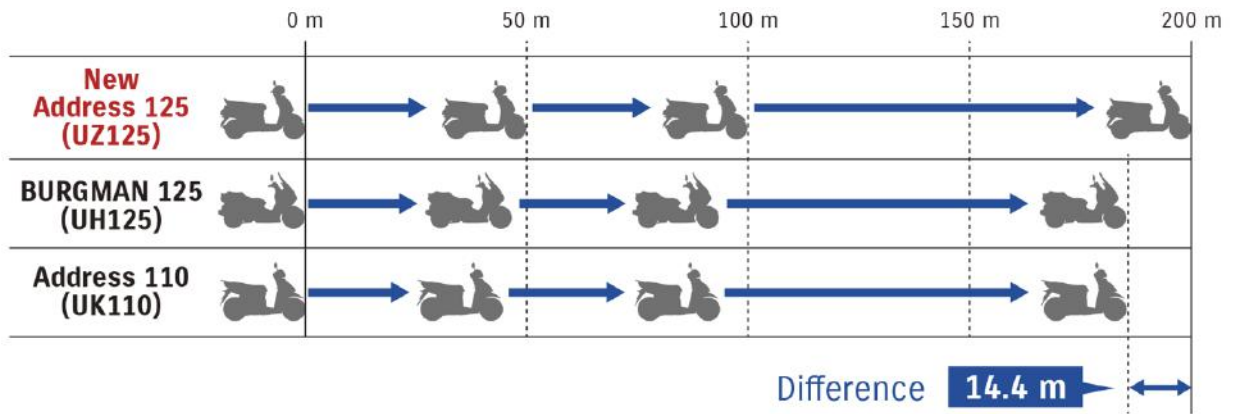

CO₂ emissions and fuel consumption comparison

European specification		CO ₂ emissions	Fuel consumption
		g/km	mpg
New model	Address 125	44	148.67
Previous models	Address 110	49	134.46
	Burgman 125	68	94.06
	Burgman 200	75	88.41

4. Engine

Engineering to optimise combustion efficiency, performance and acceleration

The engine's development is aimed at realising optimum combustion efficiency and a relatively high compression ratio, while at the same time reducing friction loss, minimising weight and noise, and optimising the CVT settings to put maximum power to the road in an efficient manner.

Suzuki Eco Performance (SEP) is the development concept behind a new generation of engines proposed by Suzuki that combine both high fuel efficiency and excellent acceleration performance. The engine in the new Address 125 was developed based on the SEP concept.

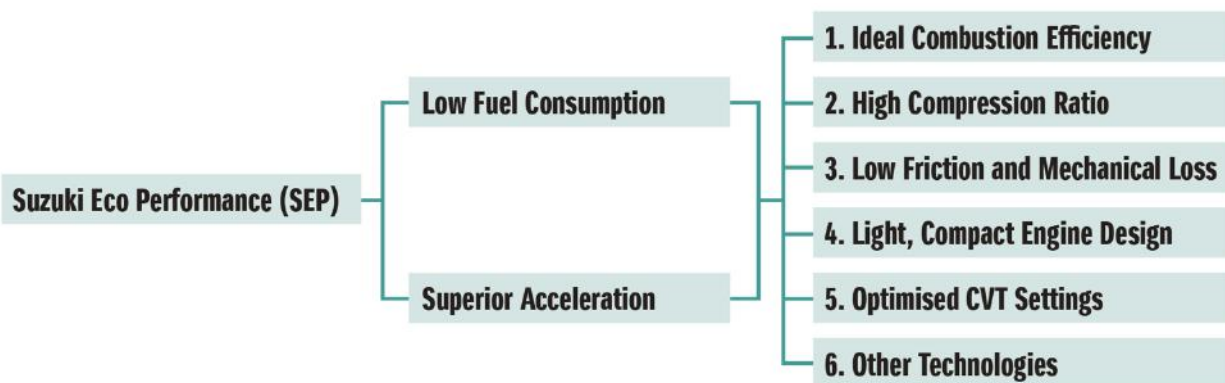

Ideal combustion efficiency

Optimisation of the intake port's shape maximises the flow velocity of the air-fuel mixture entering the combustion chamber. It combines with a chamber designed using analytic technology to generate a swirl flow that effectively disperses the mixture and controls combustion speed. The overall result is lean burning and excellent combustion efficiency that contribute both to enhancing performance and meeting Euro 5 emissions standards.

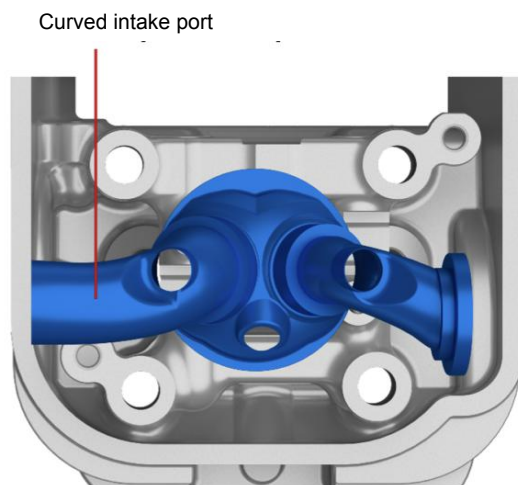
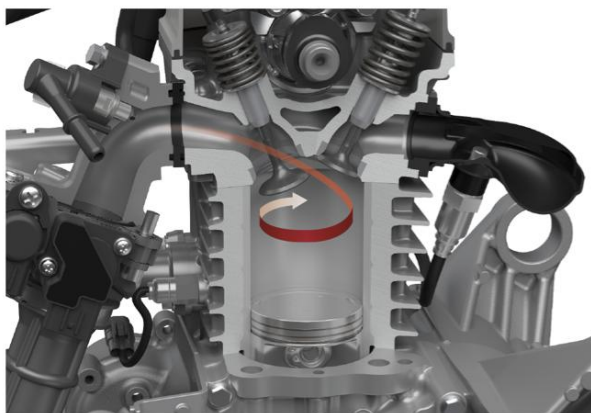

4. Engine

Suzuki 'M-Squish' combustion chamber

One feature of the combustion chamber shape is its M-shaped squish area, which generates squish flow within the chamber. In conjunction with the curved intake port, this creates ideal combustion conditions by leveraging the synergistic effect of the squish flow and the swirl flow of the air-fuel mixture entering the chamber.



Electronic fuel injection

The adoption of electronic fuel injection contributes to the Address 125's excellent combustion efficiency and helps achieve Euro 5 compliance.



4. Engine

Optimised intake valve shape

The design of the intake valve, with its two-layer chamfer and waist stem, further contributes to the overall efficiency of the intake system.

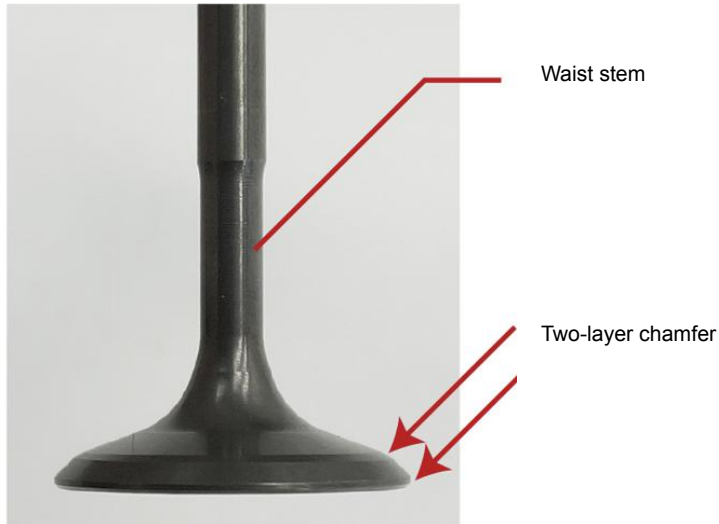

High-ignition nickel spark plug

The use of a spark plug with a thin, protruding electrode allows ignition at the centre of the combustion chamber, achieving maximum combustion efficiency. In addition, positioning the plug close to the cooling fan makes it possible to moderate the temperature area around the plug, resulting in ideal combustion.

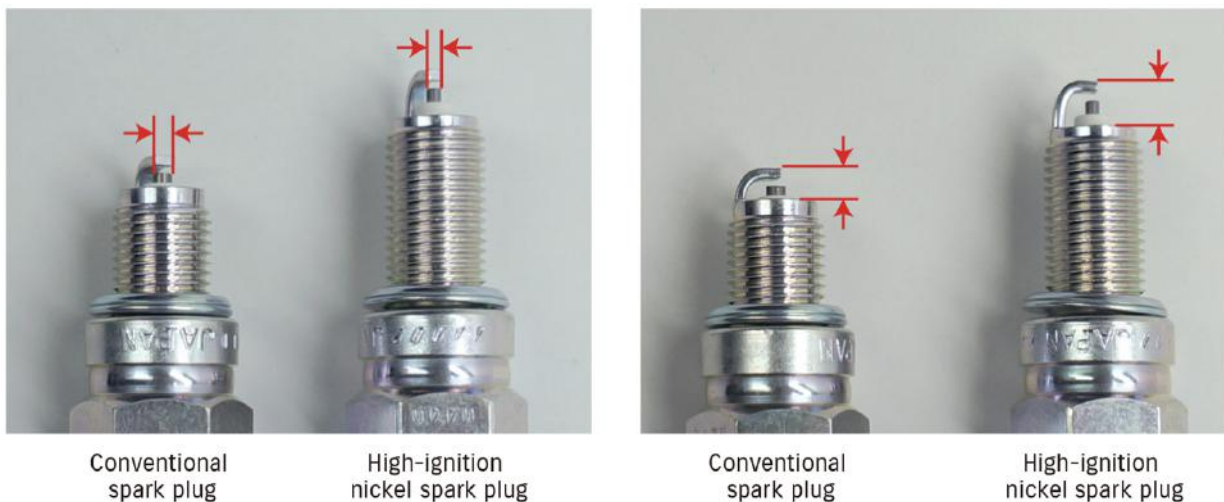

4. Engine

High compression ratio

All aspects of the engine design are geared to achieving a high compression ratio that results in low fuel consumption and powerful engine output. This ranges from the application of a relatively long stroke to optimisation of the combustion chamber shape, which, as described above, adopts an M-shaped squish area and curved intake port.

Upright positioning of the intake valve and a relatively narrow angle between the valves contributes to intake efficiency and aids the engine's high compression ratio. The design of the intake valve, with its two-layer chamfer and waist stem, further contributes to the overall efficiency of the intake system.

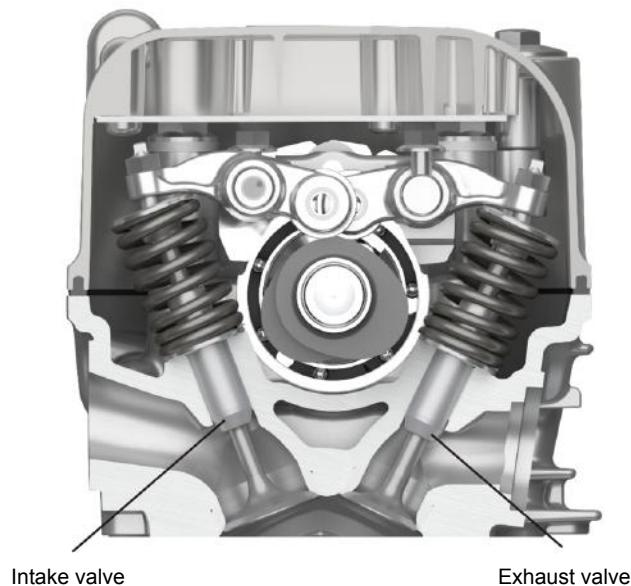

Low friction and mechanical loss

Measures to reduce friction and mechanical loss to achieve greater reliability and produce power at high rpm include an optimised piston skirt and piston pin design, as well as the use of low-tensile piston rings, a low-friction cylinder wall treatment, roller rocker arms, and low-friction components in the oil pump.



Piston and rings

4. Engine



SOHC 2-valve engine with rocker arms

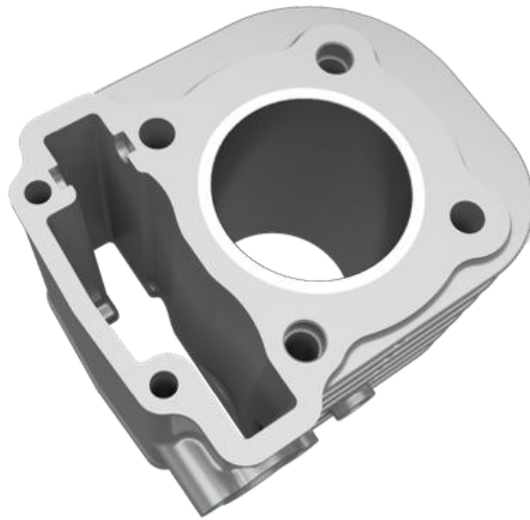

Cylinder

4. Engine

Light, compact engine design

A dedicated effort by Suzuki engineers to minimise the weight of every part possible combines with the engine's reliable single-cylinder, air-cooled design to produce a light and compact powerplant that weighs just 32.9kg. The resulting benefits not only include greater fuel efficiency, increased performance and more powerful acceleration, but they also contribute to agile handling and greater flexibility in styling design.

Optimised CVT settings

The CVT is optimised to provide satisfying acceleration at low rpm, without having to open the throttle excessively, while its settings are also effective in limiting fuel consumption.

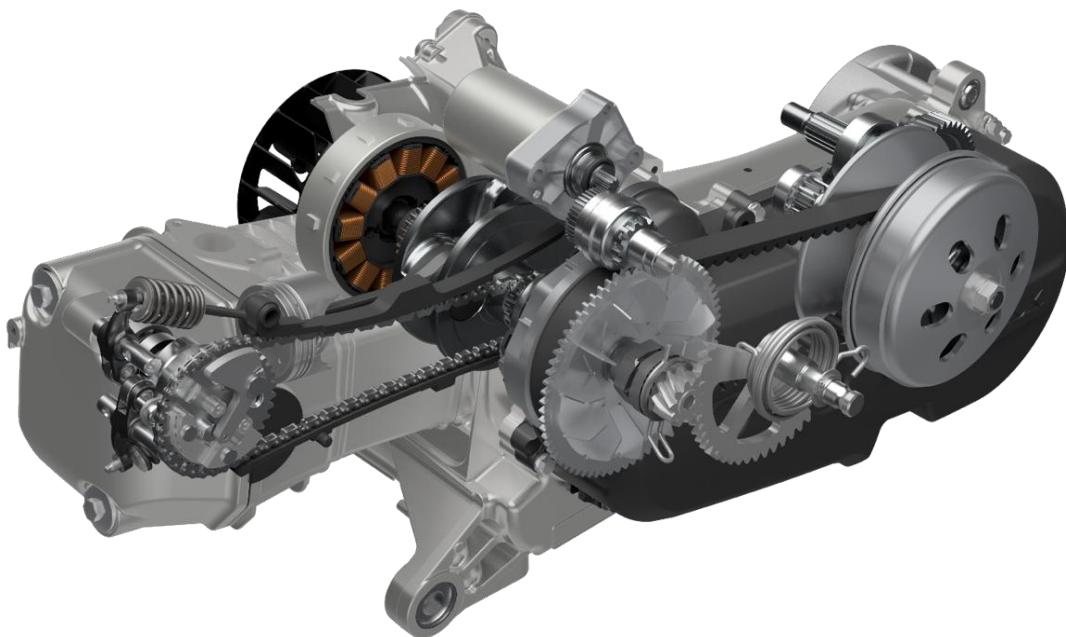

4. Engine

Other components that contribute to fuel economy, low emissions and durability

- The efficient cooling path of the cylinder head and use of a small cooling fan improve heat dissipation
- An oil filter function integrated within the engine shortens the oil path and uses a smaller volume of oil, thereby contributing to reduced mechanical loss related to the oil pump
- The starter motor gears are only engaged when starting the engine, and this reduces power loss when riding
- An electrical switch that controls ignition timing contributes to smooth power production from low to high rpm, as well as low fuel consumption
- The use of a silent cam chain contributes to a reduction in mechanical noise
- A catalytic converter fitted inside the exhaust system helps achieve Euro 5 compliance



5. Chassis

Introduction

The Address 125 uses a chassis designed for urban comfort and performance, featuring a kerb mass of just 105kg; it is designed to be easy to handle and highly manoeuvrable. Seat height and floorboard space are such that they suit a wide range of riders. Stability is excellent, with high ground clearance. The Address 125 proves its ability to excel in any urban riding situation.



5. Chassis

Lightweight and rigid pipe frame

The product of repeated simulations that employed CAE technology, the underbone frame is built using large-diameter, thin, round pipe. Designed to minimise weight while maximising rigidity, this frame contributes to the Address 125's outstanding fuel efficiency as well as to providing excellent straight-line stability and positive cornering performance.



Suspension

The semi-soft front suspension settings provide a smooth and comfortable ride, with the spring rate and operation of the telescopic front forks optimised for the front wheel weight distribution of the Address 125. Both the forks and rear suspension are finely tuned to deliver solid road-holding performance, agile handling, and a plush ride.



5. Chassis

Cast aluminium wheels and Dunlop tyres

The cast aluminium wheels are shod with tubeless Dunlop D307 N tyres. These combine with tuned suspension settings to deliver superior running performance, positive grip on wet surfaces, and a smooth ride. The rear wheel can also be removed without removing the muffler. This improves serviceability.



Combined Brake System

Suzuki's Combined Brake System supports well-balanced braking by distributing braking force to both the front and rear wheels when the left brake lever is operated. Stable stopping power is provided by a 190mm diameter disc brake in the front and a 120mm drum brake in the rear.

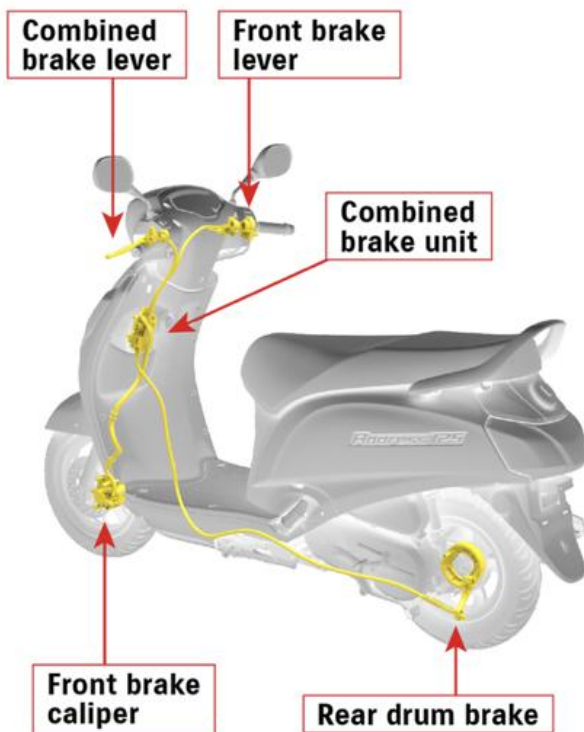

5. Chassis

Short wheelbase and light, slim design

The Address 125 rides on a short wheelbase that contributes to ease of manoeuvrability and works in conjunction with the light, slim design to offer easier, more agile handling. The slim design, low seat height and seat shape help make it easy to place both feet on the ground.

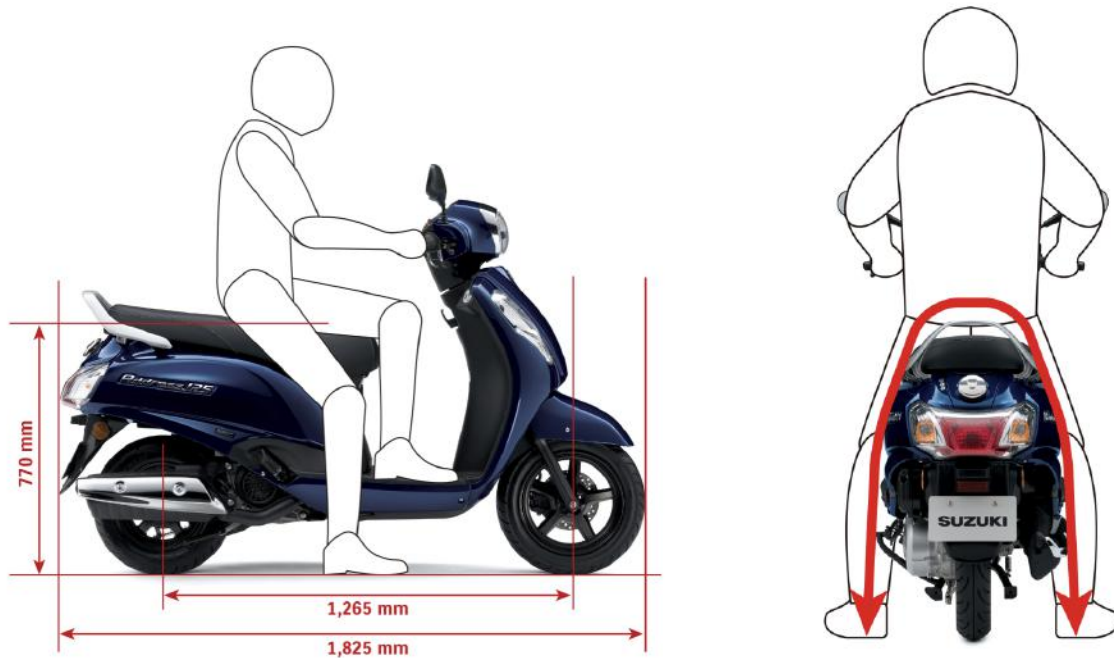

Plenty of ground clearance

The Address 125 handles speed bumps and other bumps in the road with ease thanks to its 160mm of ground clearance.



5. Chassis

Fuel tank supports a long riding range

The five litre fuel tank works in conjunction with the fuel-efficient engine to achieve a riding range of approximately 163 miles.

Comfortable seat

The long seat affords both rider and pillion plenty of room. Designed to be comfortable and well-padded to smooth out even rougher roads it is also carefully crafted shape makes it easy for the rider to plant both feet on the ground when stopped, even while the Address 125 is designed to offer ample ground clearance for leaning into corners and ably handling bumps in the road.



Steel front fender and leg shield

A steel front fender and leg shield that are resistant to damage yet in no way impede the agile handling.

Spacious floorboard

Both long and wide, the floorboard is designed to provide plenty of room for the rider to adjust their feet and find a comfortable riding position, even when carrying a passenger.

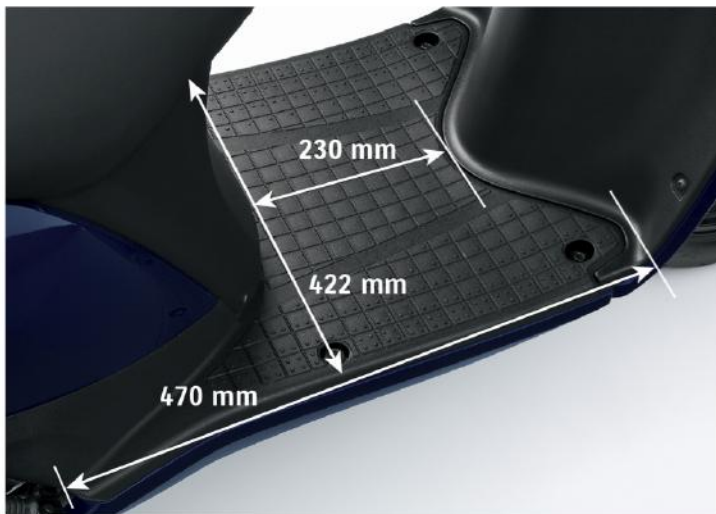

5. Chassis

Large grab bar and rubber-covered pillion footpegs

The large single-piece grab bar that runs along the back of the seat is easy for the passenger to hold on to for extra reassurance and comfort. Rubber-covered pillion footpegs fold out to dampen vibration and offer the passenger a more comfortable ride.



Tail-mounted petrol cap

The tail-mounted cap design facilitates easy refuelling and there is no risk of spillages on the floorboard or bags and other items that might be hanging from the carrying hooks. The attractive nature of the design also transforms this functional part into a stylish accent. Additionally, the cap requires a key to open, which helps make it secure against tampering.



5. Chassis

Underseat storage

With a spacious design and capacity of 21.8 litres, the underseat utility compartment can accommodate shopping bags, rain gear or other items.



Front inner pocket

The inner pocket on the front left side is easy to access, even when sitting on the scooter, perfect for small items the rider may want to keep close at hand.



Dual utility hooks

A pair of sturdy hooks let you hang various types of bags with greater convenience than accessing the underseat storage. The back hook can be locked to better secure items, and can be folded out of the way when not in use.



5. Chassis

Two underseat hooks

Two individual hooks at the front of the underseat utility compartment make it easy to hang two helmets when parking by opening the seat, attaching the helmet straps, and then closing the seat. The hooks are thick and strong.

Theft deterrent key system with seat opener function

The shutter concealing the ignition key hole can be opened quickly, using an easy-to-operate magnet mechanism coded to the owner's key, and it closes with a simple push of a button. Not only does this system help deter theft and tampering, it also includes a seat opener that eliminates the need to remove the key to access the underseat utility compartment.



Centre and side stands are both standard equipment

The Address 125 is equipped with both a centre stand and a side stand as standard.



6. Electric equipment

Analogue and digital instrumentation

The new, large analog speedometer, positioned in the centre of the instrument panel where it highlights the appeal of the Address 125's classic styling, combines with digital information displays. An LCD screen positioned in the lower centre provides fuel level, clock, voltage, odometer and dual trip displays, as well as oil change reminders.

LED indicators, designed for easy recognition, flank the speedometer. Included are indicators for the turn signals, high beam, malfunction, and master warning.

Eco Drive Illumination* lights to the left and right of the speedometer, tracing its curved shape, change from blue to green when riding in a fuel-efficient manner. Its lights show as green when riding at constant speed, accelerating slowly, decelerating, or descending hills. They show as blue when idling, accelerating quickly, ascending hills, or riding at high speed, even when the speed remains constant.



Eco Drive Illumination operating parameters

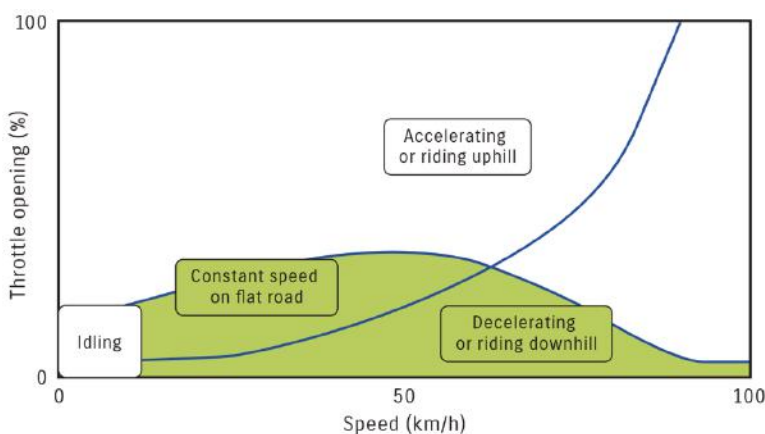

- Green when riding at constant speed or accelerating slowly
- Blue when accelerating quickly or riding up hill
- Green when decelerating or riding downhill
- Blue when riding at high speed
- Blue when idling

6. Electric equipment

LED headlight and LED position lights

The bright LED headlight features a longer and wider radiating area that better illuminates the road ahead for greater visibility. LED position lights feature a sharp vertical design that creates a signature look, and the compact LEDs employed by both bring the benefits of durability and low power consumption. A bright chrome headlight surround accentuates the Address 125's classic scooter appeal and adds a premium finish.



Integrated rear combination light

The rear combination light shows off the attractive appearance of the tail and features integrated turn signals for a sleek design.



6. Electric equipment

Suzuki Easy Start System

The system makes starting the engine as easy as one quick push of a button. There is no need to hold it down.



USB outlet included as standard equipment

Situated above the front inner pocket is a handy USB outlet that can be used to recharge a smartphone. An attractive blue LED remains lit as long as the ignition is turned on, making the outlet easy to locate, especially at night or in dark conditions.



7. Genuine accessories

Plastic top case

A large capacity top case adorned with the Suzuki logo is available for the Address 125, with a capacity of 27 litres.



Note: The separately sold rear carrier and top case adapter plate are required to install this accessory.



Cushion for top case

This accessory provides well-cushioned padding where the passenger's back meets the top case. Improves the riding comfort of the passenger.



8. Colour lineup

Metallic Dark Greenish Blue (QTZ)



Metallic Matt Bordeaux Red (QMV)



Pearl Mirage White (YPA)



9. Specification

Overall length	1,825mm (71.9 in.)	
Overall width	690mm (27.2 in.)	
Overall height	1,160mm (45.7 in.)	
Wheelbase	1,265mm (49.8 in.)	
Ground clearance	160mm (6.3 in.)	
Seat height	770mm (30.3 in.)	
Kerb mass	105kg (231.5 lbs.)	
Engine type	Four-stroke, single-cylinder, air-cooled, SOHC	
Bore x stroke	52.5mm x 57.4mm (2.1 in. x 2.3 in.)	
Engine displacement	124cc (7.6 cu. In.)	
Peak power	8.7PS (6.4 kW) / 6,750 rpm	
Peak torque	10Nm / 5,500 rpm	
Compression ratio	10.3 : 1	
Fuel system	Fuel injection	
Starter system	Electric and kick	
Lubrication system	Wet sump	
Transmission	CVT	
Suspension	Front	Telescopic, coil spring, oil damped
	Rear	Swingarm type, coil spring, oil damped
Rake / trail	26° / 89mm (3.5 in.)	
Brakes	Front	Disc
	Rear	Drum
Tires	Front	90/90-12, tubeless
	Rear	90/100-10, tubeless
Ignition system	Electronic ignition (transistorised)	
Fuel tank capacity	5.0 litres	
Fuel efficiency / range	148.67mpg / 163 miles	
CO ₂	44g/km	
Emissions standard	Euro 5	
Oil capacity (Overhaul)	0.8 litres	

ENDS