



**DR-Z
4S**

**DR-Z
4SM**

Press information

November 2024



Contents

| | |
|---|------------|
| 1. Introduction | P3 |
| 2. Product concept | P4 |
| 3. Key comparison | P7 |
| 4. Engine | P8 |
| 5. Suzuki Intelligent Ride System (SIRS) | P16 |
| 6. Chassis | P20 |
| 7. Electric equipment | P28 |
| 8. Styling design | P31 |
| 9. Colour and graphics | P33 |
| 10. Colour lineup | P35 |
| 11. Accessories | P37 |
| 12. Specification | P38 |

1. Introduction

First launched in 2000, the DR-Z400S laid the foundation for the dual sports category of today. It became an instant hit, popular with riders for its precise, agile handling and ease of manoeuvrability, allied to its easy-to-access performance. It was the go-to machine for those looking to tackle green lanes, regardless of the rider's ability or the trail's difficulty. And, with composed road manners, it made getting between the trails easy and comfortable.

Suzuki's DR-Z400 range expanded in 2005 with the introduction of an SM model. The supermoto version harnessed the punch of the 398cc single cylinder engine and the agility of the chassis, but made it even more street focussed with 17" wheels front and rear. There was now a DR-Z400 for those seeking fun off-road, and for those on in.

Sales of the DR-Z400 range ceased in the UK and Europe with the introduction of Euro 3 emissions regulations. However, calls for its return have been growing. Keen to answer consumer demand, Suzuki has launched all-new DR-Z4S and DR-Z4SM models for 2025.

The two new models satisfy Euro 5B regulations thanks to a new engine, plus a new suite of electronics and a brand new chassis. A new set of plastics takes styling cues from Suzuki's RM-Z range, with angular, sharp lines and a slim profile. The S is available in Suzuki's signature off-road yellow, as well as a classy dark grey, while the SM utilises a new blue/grey dubbed 'sky grey' and a striking white with blue wheels.

The result is a package that delivers wherever the rider cares to venture: trails and lanes to city streets and supermoto circuits. The new DR-Z4S and DR-Z4SM are all about fun.



2. Product concept

Your World. Your Playground

The product concept for The DR-Z4S and DR-Z4SM is to be fun and playful, whatever the environment, whatever world the rider chooses. From the trails to the supermoto circuit or to the city streets, the single-cylinder engine helps the DR-Z4S and DR-Z4SM leap out of turns and away from the lights, scale inclines and overcome rough terrain with ease and usability, while the chassis makes light work of corners, ruts, or urban traffic. For riders looking for smiles per cc, the DR-Z4S and DR-Z4SM deliver in droves.



2. Product concept

Key product features

Engine features:

- A new 398cc single-cylinder engine, four-valve, DOHC engine is smooth, delivering a low-midrange thrust that is maintained through to the high rpm.
- A new fuel injection system uses 10-hole injectors to maximise fuel atomisation for better combustion efficiency and lower fuel consumption.
- The new exhaust system features a dual-stage catalytic converter that helps meet Euro 5B emissions standards.
- It also uses a double-wall design that helps protect the rider's legs from heat and contributes to a slim profile.
- Dual spark plugs aid combustion efficiency and performance across the engine's operating range.
- Lightweight titanium intake valves and hollow, sodium-filled exhaust valves further boost combustion efficiency and performance.
- A new, 42mm bore electronic throttle body helps improve power output and deliver a smooth response to throttle inputs.
- Suzuki Clutch Assist System (SCAS) slipper clutch provides positive clutch engagement and provides smoother deceleration and gear changes.
- New radiator with a larger fan diameter improves cooling.
- New cam profiles contribute to greater low-end torque output, low fuel consumption, and Euro 5B emissions standards.
- Revised air box and inlet tube design helps reduce resistance, improving low-end torque production and power output.
- New piston design helps achieve smoother engine operation while reducing mechanical loss.

Chassis features:

- Brand new steel, twin-spar frame is robust to handle rough terrain and riding conditions while also enabling agile handling characteristics.
- A separate, bolt-on aluminium subframe is strong and lightweight.
- Both models use long-travel, adjustable KYB inverted front forks and a fully adjustable KYB rear shock to deliver precise steering, with optimised damping characteristics.
- 21" and 18" wheels on the S make it capable of taking on even the roughest terrain, while a pair of 17" wheels in the SM bring the fun to the asphalt.
- Front and rear disc brakes provide sure and stable stopping power, with a compact and lightweight ABS unit.
- Tapered aluminium handlebars give a solid grip and absorb shocks on rougher surfaces.
- Half-waffle grips provide optimal off-road throttle control and comfort.
- A standard-equipment aluminium skid plate protects the engine and adds to the DR-Z's purposeful image.
- Wide footpegs provide great control when negotiating trails, whether standing or sitting.
- The fuel tank is lightweight and slim
- The mirrors adopt a new tough-looking parallelogram design.

Key product features

Suzuki Intelligent Ride System (SIRS) features:

- Suzuki Drive Mode Selector gives the rider a choice of three engine maps, to suit the riding conditions.
- The Suzuki Traction Control system allows riders to choose from two modes, plus a G mode for use off-road and on looser surfaces. It can also be turned off completely.
- ABS can be disengaged at the rear or at the front and rear on the new DR-Z4S. On the DR-Z4SM it can be disengaged at the rear.
- A new ride-by-wire throttle gives riders a linear response, with the ability to adjust throttle play for finer control over the throttle action.
- Suzuki easy-start means the single-cylinder engine fires with one push of the starter button.

Electric equipment features:

- Compact dash displays important information clearly
- LED headlight incorporates both the high and low beam into one bright projector module.
- Front and rear LED indicators.
- New LED rear combination light and licence plate light feature compact designs.
- Handlebar switches are intuitive and easy to operate.

Styling features:

- Bodywork takes design cues from Suzuki's RM-Z range.
- Minimalistic styling embodies performance with modern appeal, with emphasis on sharp, flat lines.

3. Key comparison

Though many of the key components and features are shared between the DR-Z4S and DR-Z4SM, there are key differences based on their applications.

DR-Z4S



DR-Z4SM



| | | DR-Z4S | DR-Z4SM |
|--------------------------------|--------------|--|---|
| Ground clearance | | 300mm | 260mm |
| Seat height | | 920mm | 890mm |
| Weight | | 151kg | 154kg |
| Wheel size | Front | 21" | 17" |
| | Rear | 18" | 17" |
| Tyres | Front | 80/100-21M/C 51P, tube | 120/70R-17M/C 58H, tube |
| | Rear | 120/80-18M/C 62P, tube | 140/70R-17M/C 66H, tube |
| Front suspension travel | | 280mm | 260mm |
| Rear wheel travel | | 296mm | 277mm |
| ABS modes | | Front: ON. Rear: ON Front: OFF. Rear: OFF Front: ON. Rear: OFF | Front: ON. Rear: ON Front: ON. Rear: OFF |

4. Engine

Introduction

The compact 398cc, liquid-cooled, DOHC engine that powered the original DR-Z400 became known for its performance, but also its robustness and reliability. One feature that helped enable it to develop this reputation was its dry sump lubrication system, which helped give greater levels of ground clearance.

Suzuki has redesigned the engine for 2025, ensuring it hits all of its required legislation targets without sacrificing reliability and performance, making sure it produces an abundance of torque across its operating range and delivering a smooth, linear throttle response.

The introduction of a ride-by-wire electronic throttle and fuel injection system provides a neutral throttle response and gives the rider greater control. It also enables the introduction of the SIRS package.

Internally there are changes to almost every component. There are new, lightweight titanium intake valves and hollow, sodium-filled exhaust valves. New camshaft profiles provide greater intake lift and optimised valve overlap, balancing performance with Euro 5B compliance. There's a new cylinder head, with optimised shapes for the intake port, intake valve periphery, and a smooth, flat combustion chamber allows better combustion efficiency. The combination of a new piston and new crankcase reduces mechanical loss by up to 20%. The result is smoother engine operation, and increased power output to the rev limit, plus improved fuel economy.

A 42mm bore, electronic-controlled throttle body helps improve output and throttle action. Dual spark plugs contribute to smooth power delivery, lower fuel consumption, lower emissions, and a more linear throttle response. And a new inlet tube design for the air box that helps reduce resistance and boosts low-end torque.

The result is smooth torque and power throughout the engine's operating range, as well as great usability. Strong low-end power combines with increased output at higher rpm to deliver free-revving performance throughout the rev range and powerful acceleration from a standing start, making it the ideal playmate for the rider's chosen playground.



4. Engine



398cc four-stroke, liquid-cooled, DOHC engine

| | DR-Z4S | DR-Z4SM |
|---------------------------------|--|------------------|
| Displacement | 398cc | |
| Engine type | 398cc four-stroke, liquid-cooled, DOHC | |
| Bore x stroke | 90mm x 62.6mm | |
| Compression ratio | 11.1:1 | |
| Maximum power | 38PS (28kW) / 8,000rpm | |
| Maximum torque | 37Nm / 6,500rpm | |
| Fuel consumption | 80.22mpg (WMTC)* | 83.05mpg (WMTC)* |
| CO₂ emissions | 82g/km (WMTC)* | 80g/km (WMTC)* |
| Emissions level | Euro 5B | |

*World motorcycle test cycle

4. Engine



New parts highlighted in yellow

The new single-cylinder engine sees almost every component redesigned when compared to the previous generation DR-Z400S and DR-Z400SM. It includes new:

- Intake and exhaust valves.
- Intake and exhaust cams.
- Valve springs.
- Cylinder head.
- Dual spark plugs.
- Piston.
- Crankcases.
- Clutch assembly.
- Magneto.

4. Engine

High performance intake and exhaust valves

Two lightweight titanium intake valves and a pair of hollow sodium-filled exhaust valves contribute to maximising combustion efficiency and performance. By reducing weight, they allow greater freedom in designing cam profiles optimised for both power output and emissions. The hollow, sodium-filled exhaust valves help reduce temperature in the combustion chamber, which not only results in better loading efficiency and a better feeling, but also contributes to improving durability.



Camshafts



Valves

New cam profiles

The profiles of both the intake and exhaust cams deliver improved torque at low rpm, pulling cleanly to its rev limit. The intake cam increases intake air volume by increasing maximum lift and improves efficiency at low rpm, while the exhaust cam shortens the valve overlap period by changing the working angle. Each of these changes contributes significantly to enhancing output performance and reducing emissions.

4. Engine

Dual spark plugs

The new cylinder head is fitted with two iridium spark plugs, which feature heightened spark strength. The result is improved combustion efficiency at low rpm and smoother power delivery, with a linear throttle response, lower fuel consumption, and lower emissions.

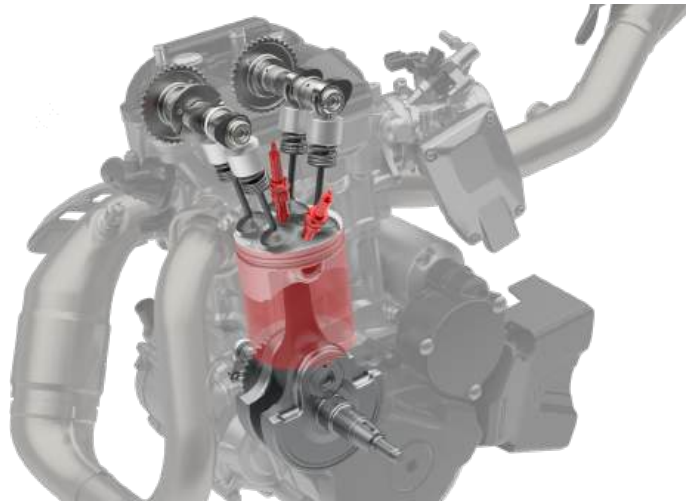

Dual spark technology

New piston design

A new piston reduces mechanical loss and delivers smooth engine operation.



Piston and piston rings

4. Engine

Suzuki Clutch Assist System (SCAS)

The new slipper clutch gives controllability and positive clutch engagement both on and off-road. The assist function leverages a precision-engineered cam to engage the clutch sleeve hub and pressure disc together and efficiently transfer torque to the rear wheel under acceleration, all while using softer clutch springs. As a result, it reduces the amount of rider input required on the clutch lever, and improves operation.

The slipper clutch partially disengages when downshifting to decelerate to mitigate the effect of engine braking, providing smoother deceleration. This function enables the rider to shift down with greater confidence and maintain better control.



Exhaust system

The new exhaust features a double-wall silencer design that helps protect the rider's legs from heat, and creates a slim profile. Both the exhaust pipe and silencer use stainless steel, which helps to greatly enhance the overall visual appeal and look of quality. The exhaust system also features a dual-stage catalytic converter and new O₂ sensor that help meet Euro 5B emissions standards.



Exhaust system

4. Engine

Fuel injection

A new fuel injection system makes the engine more controllable when riding at low speeds. By helping to achieve the ideal fuel-air ratio, the fuel injection system also results in smoother output characteristics and better response, and improved usability. The system's 10-hole fuel injector helps achieve optimal fuel atomisation for better combustion efficiency and lower fuel consumption.

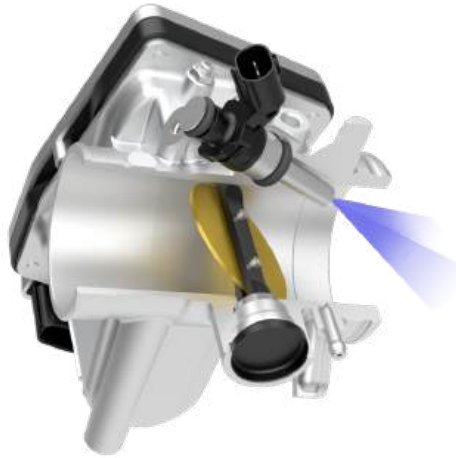

Fuel injector

Ride-by-wire throttle body

The engine is fed by a 42mm bore, electronic-controlled throttle body. This provides better power output characteristics, while also contributing to compliance with Euro 5B emissions standards. It also enables finer control.



Ride-by-wire throttle body

4. Engine

Air box and inlet

Every aspect of the new air box design, down to its capacity and outlet shape, aims to reduce intake air resistance, while the length of the inlet tube and diameter of its mouth are designed to achieve the best balance between intake air noise and output feeling to generate direct throttle response and punchy, low down torque.

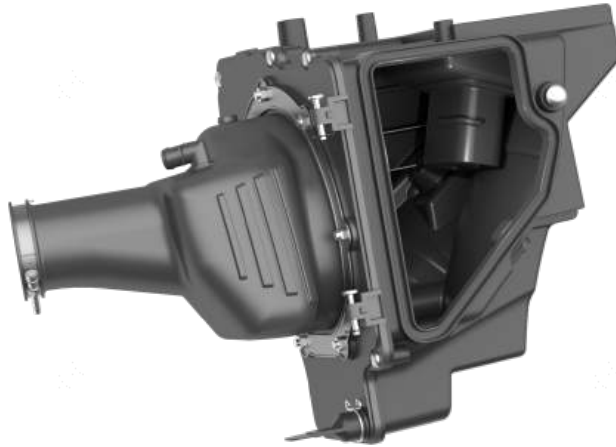

Air box (without lid)

5. Suzuki Intelligent Ride System (SIRS)

Introduction

The Suzuki Intelligent Ride System (SIRS) comprises a collection of electronic rider aids. The new DR-Z4S and DR-Z4SM are equipped with Suzuki Drive Mode Selector (SDMS), Suzuki Traction Control System (STSC), a ride-by-wire electronic throttle system, switchable ABS, and Suzuki's easy-start system.

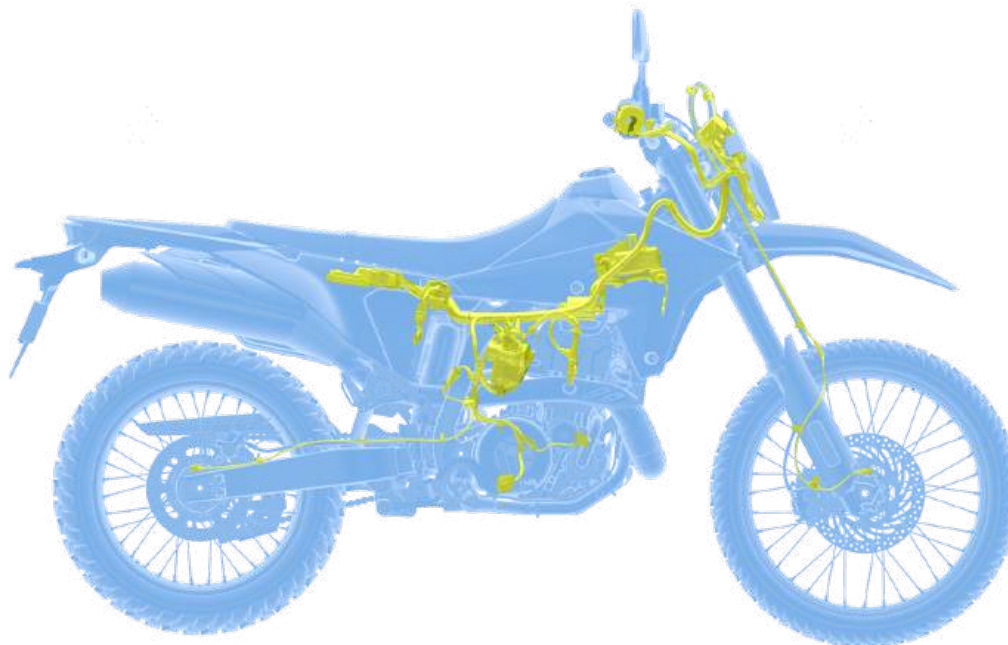

| System | Available modes | |
|------------|-----------------------|---------|
| | DR-Z4S | DR-Z4SM |
| SDMS | A - B - C | |
| STCS | 1 - 2 - G - Off | |
| Easy-start | ✓ | |
| ABS | Front: On, Rear: On | |
| | Front: On, Rear: Off | |
| | Front: Off, Rear: Off | - |

5. Suzuki Intelligent Ride System (SIRS)

Suzuki Drive Mode Selector (SDMS)

The rider can select between three modes that deliver different power characteristics to match the riding conditions. All power modes build to the same peak power.

Mode A provides the sharpest response as the throttle is opened. Tuned to deliver exciting acceleration and fully leverage the engine's power.

Mode B features a more linear curve with softer initial throttle response, to deliver a satisfying balance of settings that make a good fit for a broad range of riding styles and road conditions.

Mode C gives the softest throttle response and more gentle torque characteristic. This setting is a good choice when riding on loose or otherwise slippery surfaces.

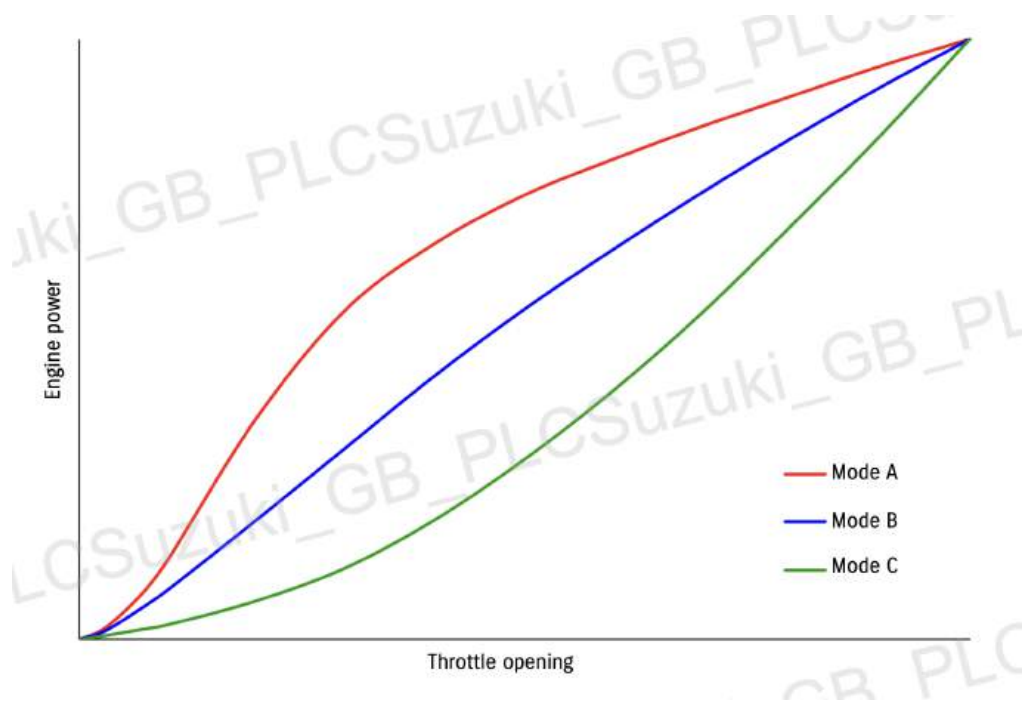

5. Suzuki Intelligent Ride System (SIRS) Suzuki Traction Control System (STCS)

The traction control system continuously monitors front and rear wheel speeds, engine rpm via the crank position sensor, throttle position, and gear position. It helps prevent rear wheel slip by retarding the ignition timing and limiting the throttle opening. Riders can choose from two standard modes, plus an additional G mode - first implemented on Suzuki's DE models in the V-Strom range - while the system can also be switched off completely.

Mode one provides the least interference of the two main modes, and is intended for dry paved surfaces, while mode two is intended for wet paved surfaces, taking effect more quickly to be more proactive in limiting wheel spin. While the settings for both the DR-Z4S and DR-Z4SM are designed for the same road surfaces, they are tuned specifically to match the differing suspension, wheels, and tyres on each model.

G (gravel) mode aims to maintain maximum off-road performance by allowing a certain amount of slip. G mode's intervention timing is set slower than for the traction control system's other two standard modes, and the maximum level of intervention is set lower. This setting provides the right balance between preventing excessive wheel spin on slippery surfaces and minimising power loss on surfaces with traction. As a result, the bike is easier to control on off-road surfaces.

The DR-Z4S and DR-Z4SM adopts its own dedicated G mode setting. On the DR-4S it focuses on enabling riders to enjoy off-road riding with confidence. It does so by adopting an updated version of the system when compared with the application on the V-Strom 1050DE and V-Strom 800DE, by being effective not only on flat surfaces but also on undulating terrain and inclines. On DR-Z4SM it is tailored more towards flat-dirt surfaces, while allowing a little more slip tolerance than on the V-Strom DEs. Allowing more spin lets the rider better tap into the model's supermoto character.

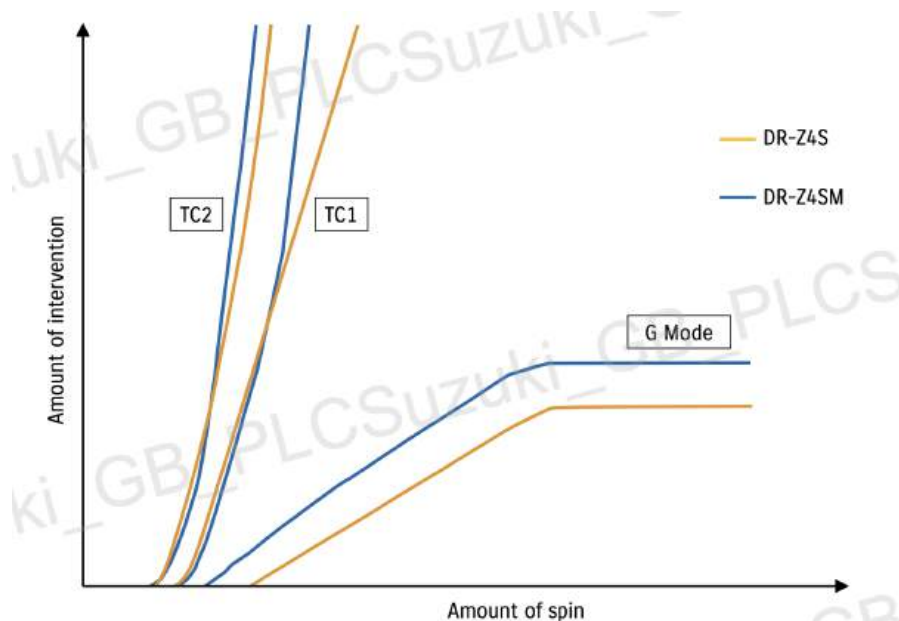

5. Suzuki Intelligent Ride System (SIRS)

Ride-by-wire electronic throttle system

The electronic throttle control system takes advantage of the ECU to control the action of the throttle valve, and make it possible for settings to control the relationship more finely between throttle action and engine output characteristics. It also means that individual settings can be tuned and thoroughly tested to match each of the SDMS modes.

The system employs a throttle cable that lets each rider adjust the amount of throttle play to suit their riding style and sensitivity to the throttle control. This makes it easy to feel where the throttle body starts to open from the point at where the play of the cable ends, contributing to an enhanced sense of operational consistency and usability.

Suzuki easy-start system

This system lets the rider start the motorcycle with one press of the starter button. There is no need to pull in the clutch lever when the transmission is in neutral, and the starter motor automatically disengages the instant the engine fires up.

6. Chassis

Introduction

A brand new frame, subframe, and swingarm have been designed to build on the previous model's reputation for precise, agile handling and easy manoeuvrability. The steel frame is rigid-yet-supple, to absorb impact and reduce rider fatigue. It is mated to a strong, lightweight aluminium subframe and swingarm that helps provide a comfortable ride.

Suspension on both the DR-Z4S and DR-Z4SM comes in the form of long-travel suspension from KYB, specifically tuned for each model's intended application.

The DR-Z4S has a 21" front wheel and an 18" rear, shod with IRC GP-410 dual-purpose tyres, while the DR-Z4SM's 17" front and rear wheels are fitted with Dunlop SPORTMAX Q5A tyres.

Tapered aluminium handlebars are fitted with half-waffle grips that mitigate shock to the hands and are easier to control.

As a result, the new DR-Z4S and DR-Z4SM achieve the right balance of performance, stability, and agility to excel both on and off the road.

DR-Z4S



DR-Z4SM



6. Chassis

Twin-spar steel frame, aluminium subframe and swingarm

A new twin-spar frame is designed to provide stability and instil confidence, making the DR-Z4S an effective tool on twisty trails and green lanes, and to make the DR-Z4SM handle superbly on the supermoto circuit and in urban settings.

The frame is manufactured from steel, making it rigid, strong, and supple to handle rough surfaces and absorbs shocks to reduce rider fatigue. The separate lightweight aluminium subframe is strong to support the rider, and the lightweight aluminium swingarm helps improve tracking and rear suspension response, contributing to a smooth and comfortable ride.



6. Chassis



6. Chassis

Wheels and tyres

The DR-Z4S is fitted with wire-spoked wheels, with a 21" front and 18" rear. Tyres are IRC GP-410, dual purpose, tubed tyres (80/100-21M/C front, 120/80-18M/C rear). Built to perform off-road or on it, they feature chunky centre blocks that provide solid grip and contribute to the model's usability.

The SM is fitted with 17" rims and Dunlop SPORTMAX Q5A tyres (120/70R17M/C front, 140/70R17M/C rear). These performance street tyres use a silica compound, which provides both dry and wet grip, as well as excellent reinforcement for longer life.

DR-Z4S



Front wheel and tyre



Rear wheel and tyre

DR-Z4SM



Front wheel and tyre



Rear wheel and tyre

6. Chassis

Suspension

Both models use long-travel, adjustable KYB inverted front forks and KYB rear shock, with the base settings tailored for each model. The DR-Z4S has 280mm of front fork travel and 296mm of rear wheel travel, and the DR-Z4SM has 260mm of front suspension travel and 277mm of rear wheel travel. Both have compression and rebound damping adjustment, front and rear.

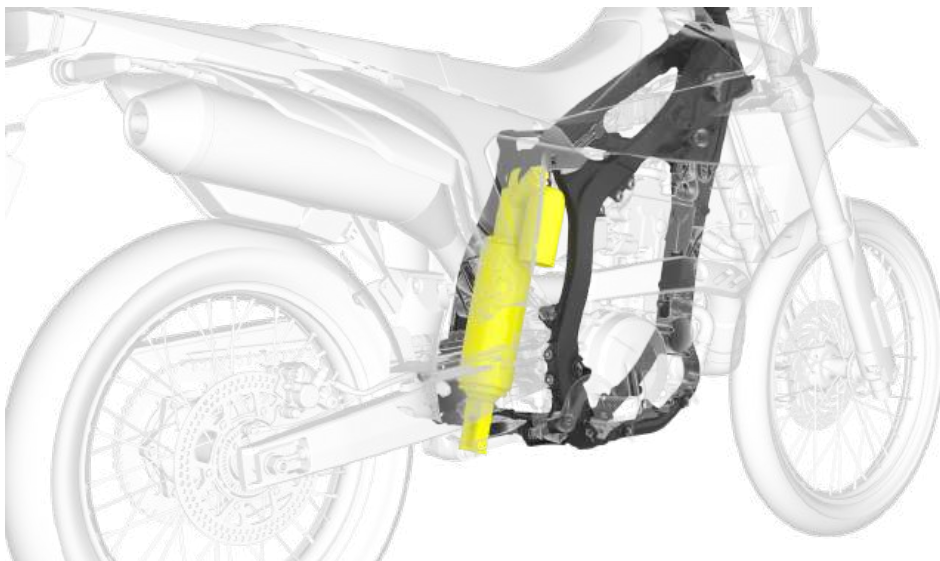

6. Chassis

Additional features

- Light, strong, and flexible tapered aluminium handlebars provide a solid grip and help absorb bumps on rough surfaces.
- The ABS unit from Bosch is compact and lightweight.



- Single front discs are 270mm in diameter on the DR-Z4S and 310mm on the DR-Z4SM.
- Both are fitted with a 240mm rear disc.
- Axial-mounted calipers provide performance and resistance to vibrations when riding over rough terrain.
- Half-waffle design grips distribute pressure across the palms and make the grips easier to hold, aiding control and greatly reducing rider fatigue.



6. Chassis

Additional features

- The seat width provides comfort and is highly durable to support the rider well when shifting body weight. Its narrow design makes standing easy and comfortable.



- An aluminium skid plate is standard and provides protection.



6. Chassis

Additional features

- Wide foot pegs provide solid footing and stability when standing or sitting.



- The fuel tank is lightweight and slim, with a capacity of 8.7 litres.



- The mirror shape features a tough-looking parallelogram design.



7. Electric equipment

Compact LCD instrument display

The DR-Z4S and SM are fitted with an LCD instrument panel that is light and compact, featuring a clearly legible display.

LCD readouts include:

Speedometer

SDMS mode

Odometer

Traction control mode

Dual trip meter

Instant fuel consumption

Gear position indicator

Average fuel consumption

Voltmeter

Fuel gauge

Clock



LED indicators flanking the display include the turn signal indicator, MIL (malfunction indication lamp), master warning indicator, low voltage warning indicator, coolant temperature warning light, ABS function indicator, neutral indicator light, ABS warning indicator, traction control indicator, and high beam indicator. All are designed for easy recognition.

7. Electric equipment

LED headlight

The LED headlight incorporates both the high and low beam into one bright projector module that is compact, light, and highly durable.



Headlight assembly



Ignition off



Low beam on



High beam on

7. Electric equipment

Position lights with integrated indicators

The left and right LED position lights and indicators are combined into single assemblies. The position light projects a steady orange light until the rider switches on an indicator, at which point it begins flashing in orange.



Front indicators on

LED rear combination and licence plate light

LEDs used for the rear combination lights and licence plate light feature compact designs that are highly visible and durable.



Ignition off



Indicator off



Indicators on

Handlebar switches

The handlebar switches are designed for easy and intuitive operation, meaning riders can seamlessly switch between modes without breaking their concentration on the ride.



Left handlebar switch



Right handlebar switch

8. Styling design

The new DR-Z4S and DR-Z4SM are designed to emphasise agile performance with a linear connection from front to rear. The focus was on establishing a bold horizontal line along the sides that cuts right from the front fender through to the tail.

The strong image of these models is a major point of appeal for the styling. Ergonomics was the driving force behind every aspect of the design. By shaving away all excess elements, Suzuki visually expresses the functionality of both bikes and exposes their authentic appeal.



The flat, flush design is not only thoroughly modern, but it also benefits the rider by aiding in freedom of movement. It is a slim design that positions its bodywork higher up to raise the centre of gravity.

Ergonomics played a key role in the new design. The DR-Z4S and DR-Z4SM are designed to not interfere in any way with the rider and their movement. Functional parts such as the engine, swingarm, and suspension are designed to heighten the visual appeal bikes. The exposed parts that are not covered by the bodywork are carefully sculpted and surface-treated to maintain the design's overall balance, and to convey the look of functional beauty and quality.

8. Styling design



9. Colour and graphics

Colours

Modern, simple graphics and trendsetting colours complement the bodywork. The DR-Z4S and DR-Z4SM are each available in a choice of two colour schemes.

The DR-Z4S comes in Champion Yellow No. 2 / Solid Special White No. 2 (C1C) which pays homage back to the heritage of the DR-Z desert racer and pays tribute to the heritage of Suzuki's motocross machines. It also comes in Solid Iron Grey (YUD)

The DR-Z4SM comes in Sky Grey (Q1T), which is a new colour developed for the new DR-Z4SM. While robust and functional, it also reflects a sense of modern urban styling. This blue/grey colour conveys a sense of sophistication and elegance. It lends the new model a fresh new look and reflects the improvements it brings in terms of both performance and quality. The DR-Z4SM will also be available in Solid Special White No. 2 (30H).

DR-Z4S



Champion Yellow No. 2 / Solid Special White No.2 (C1C)

DR-Z4SM



Sky Grey (Q1T)

9. Colour and graphics

Graphics

The graphics adorning the new DR-Z4S and DR-Z4SM are simple-yet-impactful.

The 'DR-Z' decals on each side of the cowling, in front of the engine, are modern and simple. Following the horizontal line along the cowling, these decals feature a colourful gradation below the lettering that reflects the modern image of the DR-Z. For each colour option, a different chromatic colour is used to maximise the effect.

An embossed 'S' logo proudly adorns the centre of the front shroud.



10. Colour lineup



Champion Yellow No. 2 /
Solid Special White No.2
(C1C)



Solid Iron Grey (YUD)

10. Colour lineup



Sky Grey (Q1T)



Solid Special White No. 2
(30H)

11. Accessories



Hand guards
S SM



DC socket
S SM



Front brake disc cover
S (not in combination with front axle slider)



Rear brake disc cover
S SM



Front axle slider
S SM (not in combination with front brake disc cover)



Rear axle slider
S SM



Aluminium skid plate
S SM



Low seat - 30mm lower than standard
S SM



Rear carrier
S SM

12. Specification

| | DR-Z4S | | DR-Z4SM | |
|---------------------------------|---|--|-------------------------|--|
| Overall length | 2,270mm (89.4in.) | | 2,195mm (86.4in.) | |
| Overall width | 885mm (34.8in.) | | 885mm (34.8in.) | |
| Overall height | 1,230mm (48.6in.) | | 1,190mm (46.9in.) | |
| Wheelbase | 1,490mm (58.9in.) | | 1,465mm (57.7in.) | |
| Ground clearance | 300mm (11.8in.) | | 260mm (10.2in.) | |
| Seat height | 920mm (36.2in.) | | 890mm (35.0in.) | |
| Kerb mass | 151kg (333lbs.) | | 154kg (340lbs.) | |
| Engine type | Four-stroke, single-cylinder, liquid-cooled, DOHC | | | |
| Bore x stroke | 90mm x 62.6mm (3.5in. x 2.5in.) | | | |
| Engine displacement | 398cc (24.3 cu. in.) | | | |
| Peak power | 38PS (28kW) / 8,000rpm | | | |
| Peak torque | 37Nm / 6,500rpm | | | |
| Compression ratio | 11.1:1 | | | |
| Fuel system | Fuel injection | | | |
| Starter system | Electric | | | |
| Lubrication system | Dry sump | | | |
| Transmission | Five-speed constant mesh | | | |
| Suspension | Front | Inverted telescopic, coil spring, oil damped | | |
| | Rear | Link type, coil spring, oil damped | | |
| Rake / trail | 27.5° / 109mm (4.29in.) | | 26.5° / 95mm (3.74in.) | |
| Brake | Front | Disc | | |
| | Rear | Disc | | |
| Tyres | Front | 80/100-21M/C 51P, tube | 120/70R-17M/C 58H, tube | |
| | Rear | 120/80-18M/C 62P, tube | 140/70R-17M/C 66H, tube | |
| Ignition system | Electronic ignition | | | |
| Fuel tank capacity | 8.7L (1.9 gallons) | | | |
| Oil capacity (overhaul) | 1.9L (1.7 quart) | | | |
| Fuel consumption | 80.22mpg (WMTC) | | 83.05mpg (WMTC) | |
| CO₂ emissions | 82g/km (WMTC) | | 80g/km (WMTC) | |

Ends